



LAKIREDDY BALI REDDY COLLEGE OF ENGINEERING (AUTONOMOUS)

L.B. Reddy Nagar :: Mylavaram-521 230 :: NTR Dist. :: A.P
Approved by AICTE, New Delhi. Affiliated to JNTUK, Kakinada

B.Tech. (II Semester) (R23) Semester End Examinations (Supplementary) – December 2025

TIME TABLE

R23

Time : 10.00 A.M. to 01.00 P.M.

A.Y. : 2025-26

Branch	02-12-2025 (Tuesday)	03-12-2025 (Wednesday)	04-12-2025 (Thursday)	05-12-2025 (Friday)	06-12-2025 (Saturday)
AI & DS	23ME01-Engineering Graphics	23FE05-Differential Equations & Vector Calculus	23FE04-Engineering Physics	23EE01-Basic Electrical & Electronics Engineering	23CS02-Data Structures
ASE	23FE06-Engineering Chemistry	23FE05-Differential Equations & Vector Calculus	23CS01-Introduction to Programming	23EE01-Basic Electrical & Electronics Engineering	23ME02-Engineering Mechanics
CE	23FE06-Engineering Chemistry	23FE05-Differential Equations & Vector Calculus	23CS01-Introduction to Programming	23EE01-Basic Electrical & Electronics Engineering	23ME02-Engineering Mechanics
CSE	23ME01-Engineering Graphics	23FE05-Differential Equations & Vector Calculus	23FE04-Engineering Physics	23EE01-Basic Electrical & Electronics Engineering	23CS02-Data Structures
CSE (AI & ML)	23ME01-Engineering Graphics	23FE05-Differential Equations & Vector Calculus	23FE04-Engineering Physics	23EE01-Basic Electrical & Electronics Engineering	23CS02-Data Structures
ECE	23FE02-Chemistry	23FE05-Differential Equations & Vector Calculus	23CS01-Introduction to Programming	23CM01-Basic Civil & Mechanical Engineering	23EC01-Network Analysis
EEE	23FE02-Chemistry	23FE05-Differential Equations & Vector Calculus	23CS01-Introduction to Programming	23CM01-Basic Civil & Mechanical Engineering	23EE02-Electrical Circuit Analysis-I
IT	23ME01-Engineering Graphics	23FE05-Differential Equations & Vector Calculus	23FE04-Engineering Physics	23EE01-Basic Electrical & Electronics Engineering	23CS02-Data Structures
ME	23FE06-Engineering Chemistry	23FE05-Differential Equations & Vector Calculus	23CS01-Introduction to Programming	23EE01-Basic Electrical & Electronics Engineering	23ME02-Engineering Mechanics

Note(s): 1. Any omissions or clashes in the time table may please be informed to the Controller of Examinations immediately.

2. There is no objective paper for Engineering Graphics subject.

Date: 14-11-2025

CONTROLLER OF EXAMINATIONS**PRINCIPAL**Copy to: 1. Vice-Principal, Deans & HoDs, 2. T&P cell, Transport in-charge & Librarian
3. Canteen, PD, Security & Hostels 4. Coordinator-Disciplinary 5. Notice Boards

LAKIREDDY BALI REDDY COLLEGE OF ENGINEERING (AUTONOMOUS)

L.B.Reddy Nagar :: Mylavaram – 521 230 :: NTR Dist. :: A.P.

B.Tech. (II Semester) ~~Regular~~/Supplementary Examinations**23ME01-ENGINEERING GRAPHICS**

(AI&DS,CSE,CSE(AI&ML) and IT)

p. 2 ✓

Time : 3 hours

Max. Marks : 70

Q.No	All questions carry equal marks	Marks	CO	BL
1(a)	Construct an ellipse when the distance of the focus from the directrix is equal to 50 mm and eccentricity is $2/3$. Draw tangent and normal at a point 40 mm from the directrix.	7M	CO1	L2
(b)	Draw involute of a regular pentagon of side 20 mm. Draw its tangent and normal at 80 mm of the center of the pentagon.	7M	CO1	L2
(OR)				
2(a)	Draw the projections of the following points on the same ground line keeping the projections 25 mm apart (i) A is 20 mm above H.P. and 30 mm in front of V.P (ii) B is on H.P. and 30 mm in front of V.P. (iii) C is on V.P. and 35 mm above H.P (iv) D is 25 mm above H.P. and 35 mm behind V.P.	7M	CO1	L2
(b)	A point P is 15 mm above the H.P. and 20 mm in front of the V.P. Another point Q is 25 mm behind the V.P. and 40 mm below the H.P. Draw the projections of P and Q keeping the distance between the end projectors equal to 90 mm. Draw the straight lines joining (i) their top views and (ii) their front views.	7M	CO1	L2
(OR)				
3(a)	A 70 mm long line is parallel to and 40 mm above H.P. Its two ends are 25 mm and 50 mm in front of V.P respectively. Draw its projections and find the inclination with the V.P.	7M	CO2	L2
(b)	Two pegs fixed on a wall are 4.5 m apart. The distance between the pegs measured parallel to the floor is 3.6 m. If one peg is 1.5 m above the floor, find the height of the second peg and the inclination of the line joining two pegs, with the floor.	7M	CO2	L3
(OR)				
4(a)	A square plane ABCD of side 30 mm is parallel to H.P. and 20 mm above it. Draw the projections of the plane when two of its sides are parallel to V.P.	7M	CO2	L2
(b)	Draw the projections of a regular pentagon 25 mm side with its surface making an angle of 45° with H.P and perpendicular to the V.P. One of the sides of the pentagon is parallel to H.P. and 15 mm above it.	7M	CO2	L3
(OR)				
5(a)	Draw the projections of a hexagonal pyramid, with side of base 30mm and axis 70 mm long, which is resting with a slant face on H.P such that, the axis is parallel to V.P.	7M	CO3	L3
(b)	Draw the projections of a cylinder of 40 mm diameter and axis 60mm long, when it is lying on H.P, with its axis is inclined at 45° with H.P. and parallel to V.P.	7M	CO3	L3
(OR)				
6(a)	A triangular prism of base 30 mm side and axis 50 mm long, is resting on H.P on one of its bases, with a face 45° to the V.P. Draw the projections of the solid.	7M	CO3	L3

LAKIREDDY BALI REDDY COLLEGE OF ENGINEERING(AUTONOMOUS)

L.B.Reddy Nagar :: Mylavaram – 521 230 :: NTR Dist.:: A.P.

B.Tech. (II Semester) ~~Regular~~/Supplementary Examinations**23FE06-ENGINEERING CHEMISTRY**

(ASE,CE&ME)

Time : 3 hours

Max. Marks : 70

Q.No	Compulsory Question	Marks	CO	BL
1(a)	Define priming and foaming.	2M	CO1	L1
(b)	What is reverse osmosis?	2M	CO1	L1
(c)	Define electrochemical series.	2M	CO2	L1
(d)	Write the names of anode and cathode used in zinc-air battery.	2M	CO2	L1
(e)	Mention two examples of condensation polymers.	2M	CO3	L1
(f)	What is meant by functionality?	2M	CO3	L1
(g)	Write classification of refractories based on chemical composition.	2M	CO4	L1
(h)	Mention approximate time required for setting and hardening of cement.	2M	CO4	L1
(i)	Give any two applications of nanomaterials.	2M	CO5	L1
(j)	Outline any two differences between physi-sorption and chemi-sorption.	2M	CO5	L1
Q.No	All questions carry equal marks	Marks	CO	BL
2(a)	How scales and sludge's are formed in boilers? Discuss disadvantages of scales and sludges.	5M	CO1	L2
(b)	Explain the determination of hardness using EDTA method.	5M	CO1	L2
(OR)				
3(a)	Justify the following statement. "Water softened by Lime soda process damages boiler material".	5M	CO1	L2
(b)	Explain the electro-dialysis process used to obtain soft water from sea water.	5M	CO1	L2
4(a)	Explain the reactions involved in the Li-ion battery during discharging and charging.	5M	CO2	L2
(b)	What is meant by water line corrosion?	5M	CO2	L2
(OR)				
5(a)	Outline the factors that can affect the corrosion.	5M	CO2	L2
(b)	Explain the construction and working phenomenon of hydrogen-oxygen fuel cell with a neat sketch.	5M	CO2	L2
6(a)	How to carry out proximate analysis of coal.	5M	CO3	L2
(b)	Differentiate thermoplastic and thermosetting polymers.	5M	CO3	L2
(OR)				
7(a)	Write the preparation, properties and applications of Polystyrene.	5M	CO3	L2
(b)	Write a brief note on addition polymerization.	5M	CO3	L2
8(a)	Discuss the classification of refractories.	5M	CO4	L2
(b)	Summarize the advantages of using composites.	5M	CO4	L2
(OR)				
9(a)	Discuss the setting and hardening of cement with chemical reactions.	5M	CO4	L2
(b)	Outline the characteristics of good lubricant.	5M	CO4	L2
10(a)	Summarize the applications of colloids.	5M	CO5	L2
(b)	Discuss the stabilization methods of nanomaterials by using stabilizing agents.	5M	CO5	L2
(OR)				
11(a)	How to prepare colloids using Bredig's arc method?	5M	CO5	L2
(b)	Explain the Freundlich adsorption isotherm curve.	5M	CO5	L2

LAKIREDDY BALI REDDY COLLEGE OF ENGINEERING(AUTONOMOUS)

L.B.Reddy Nagar :: Mylavaram – 521 230 :: NTR Dist.:: A.P.

B.Tech. (II Semester) ~~Regular~~/Supplementary Examinations**23FE02-CHEMISTRY**

(ECE&EEE)

Time : 3 hours

Max. Marks : 70

Q.No	Compulsory Question	Marks	CO	BL
1 (a)	Calculate bond order of Helium molecule .	2M	CO1	L1
(b)	Explain photoelectric effect.	2M	CO1	L1
(c)	How many pentagons and hexagons exist in fullerene (C60)?	2M	CO2	L1
(d)	Which compound can act as p dopant and n dopant in semiconductors?	2M	CO2	L1
(e)	Define the term electrochemical sensor.	2M	CO3	L1
(f)	Define the terms functionality and degree of polymerization.	2M	CO3	L1
(g)	Illustrate homo chain and hetero chain polymers.	2M	CO4	L1
(h)	Write the names of monomers of nylon6:6.	2M	CO4	L1
(i)	State the principle of chromatography.	2M	CO5	L1
(j)	Narrate the importance of fingerprint region in IR spectroscopy.	2M	CO5	L1
Q.No	All questions carry equal marks	Marks	CO	BL
2(a)	Justify the following statement in terms of molecular orbital theory. "Oxygen molecule is paramagnetic in nature".	5M	CO1	L2
(b)	Explain pi molecular orbitals of benzene.	5M	CO1	L2
(OR)				
3(a)	Derive the energy of a particle in a one dimensional box using the Schrodinger time independent equation.	5M	CO1	L2
(b)	Apply molecular orbital theory to NO molecule.	5M	CO1	L2
4(a)	Discuss the conduction process in p doped semiconductors.	5M	CO2	L2
(b)	Differentiate type1 and type2 superconductors.	5M	CO2	L2
(OR)				
5(a)	Explain the construction of pseudo super capacitors.	5M	CO2	L2
(b)	Outline the properties and applications of fullerene.	5M	CO2	L2
6(a)	Calculate the EMF of the following cell at 298 K. $X(s) / X^{2+} (0.001M) // Y^{2+} (0.0001M) / Y(s)$ $E_0 Y^{2+}/ Y = 0.34V; E_0 X^{2+}/X = -2.37 V$	5M	CO3	L3
(b)	Explain potentiometric titration of redox titration is found using it.	5M	CO3	L2
(OR)				
7(a)	Describe the design and functioning of the H ₂ – O ₂ fuel cell.	5M	CO3	L2
(b)	Discuss conductometric titration of strong acid vs. strong base.	5M	CO3	L2
8(a)	Differentiate thermosets and thermoplasts.	5M	CO4	L2
(b)	Explain mechanism of conduction in polyacetylene.	5M	CO4	L2
(OR)				
9(a)	How to prepare Teflon? Give properties and applications.	5M	CO4	L2
(b)	Describe the mechanism of free radical addition polymerization.	5M	CO4	L2
10(a)	Explain the instrumentation of UV-visible spectroscopy.	5M	CO5	L2
(b)	Summarize the applications of IR spectroscopy.	5M	CO5	L2
(OR)				
11(a)	How shifts of absorption and intensity occur in UV-visible spectroscopy?	5M	CO5	L2
(b)	Explain the instrumentation of high power liquid chromatography (HPLC).	5M	CO5	L2

LAKIREDDY BALI REDDY COLLEGE OF ENGINEERING (AUTONOMOUS)

L.B.Reddy Nagar :: Mylavaram – 521 230 :: NTR Dist. :: A.P.

B.Tech. (II Semester) Regular/Supplementary Examinations

23FE05-DIFFERENTIAL EQUATIONS & VECTOR CALCULUS

(Common to All)

Time : 3 hours

Max. Marks : 70

Buseef
03/12/25

Q.No	Compulsory Question	Marks	CO	BL
1(a)	Investigate the integrating factor of $x \frac{dy}{dx} - y = 2x^2 \operatorname{cosec} 2x$.	2M	CO1	L2
(b)	Write the mathematical formulation of Law of cooling.	2M	CO1	L1
(c)	Evaluate the complementary function of $(D^2 + 4D + 5)y = 0$.	2M	CO1	L2
(d)	Evaluate $\frac{1}{D-3} x$.	2M	CO1	L2
(e)	Find a Partial differential equation by eliminating the arbitrary constants in $z = axy + b$	2M	CO2	L2
(f)	Find the complete solution of $p\sqrt{x} + q\sqrt{y} = \sqrt{z}$	2M	CO2	L2
(g)	If $\vec{r} = x\vec{i} + y\vec{j} + z\vec{k}$ then write 'r' value	2M	CO3	L2
(h)	Find the gradient of $f = x^2 yz^3$ at $(2, 1, -1)$	2M	CO3	L2
(i)	Show that $\vec{F} = (e^x z - 2xy)\vec{i} - (x^2 - 1)\vec{j} + (e^x + z)\vec{k}$ is conservative.	2M	CO4	L2
(j)	State Stoke's theorem.	2M	CO4	L1
(OR)				
Q.No	All questions carry equal marks	Marks	CO	BL
2(a)	Solve $(y \cos x - 2x)dx + (\sin x + \cos y)dy = 0$.	5M	CO1	L3
(b)	If the temperature of the air is 25°C and the temperature of the body drops from 100°C to 80°C in 10 minutes, what will be the temperature of the body after 20 minutes?	5M	CO1	L3
(OR)				
3(a)	Solve $\frac{dy}{dx} = \frac{1}{(1+x^2)}(e^{\tan^{-1}x} - y)$	5M	CO1	L3
(b)	Bacteria in a certain culture increases at a rate proportional to the number present. If the number N increases from 1000 to 2000 in one hour, how many are present at the end of 1.5 hours	5M	CO1	L3
(OR)				
4(a)	Solve $(D^3 - 5D^2 + 8D - 4)y = e^{2x} + e^{6x}$	5M	CO1	L3
(b)	Apply method of variation of parameters to find the complete solution of $(D^2 + 4)y = \tan 2x$.	5M	CO1	L3
(OR)				
5(a)	Find complete solution of $(D^2 + 1)y = \sin x \cdot \sin 2x$.	5M	CO1	L3
(b)	Solve $\frac{dx}{dt} = x - 2y, \frac{dy}{dt} = 5x + 3y$.	5M	CO1	L3
(OR)				
6(a)	Form the partial differential equation by eliminating the arbitrary function $F(xy + z^2, x + y + z) = 0$.	5M	CO2	L3
(b)	Solve the Lagrange's equation $x(y - z)p + y(z - x)q = z(x - y)$	5M	CO2	L3
(OR)				
7(a)	Generate the partial differential equation by eliminating the arbitrary constants a and b from $2z = \sqrt{(x+a)} + \sqrt{(y+b)}$.	5M	CO2	L3

23FE05-DIFFERENTIAL EQUATIONS & VECTOR CALCULUS

(b)	Solve $(D^3 - 3D^2D' + 4(D')^3)z = e^{x+2y}$	5M	CO2	L3
8(a)	Find the directional derivative $\phi = xy^2 + yz^2$ in the direction of the vector $\vec{i} + 2\vec{j} + 2\vec{k}$ at the point $(2, -1, 1)$.	5M	CO3	L3
(b)	If $\vec{f} = xy^2\vec{i} + 4x^2yz\vec{j} - 2yz^2\vec{k}$ find $\text{div}\vec{f}$ at $(1, -2, 3)$.	5M	CO3	L3
(OR)				
9(a)	If the given function $\vec{A} = (x+2y+az)\vec{i} + (bx-3y-z)\vec{j} + (4x+cy+2z)\vec{k}$ is irrotational, find the constants a, b, c.	5M	CO3	L3
(b)	Calculate the angle between the surfaces $xy^2z = 3x + z^2$ and $3x^2 - y^2 + 2z = 1$ at the point $(1, -2, 1)$.	5M	CO3	L3
10.	Verify by Green's theorem in the plane for $\int_C (x^2 - xy^3)dx + (y^2 - 2xy)dy$ where C is the Square with vertices $(0,0)$, $(2,0)$, $(2,2)$ and $(0,2)$.	10M	CO4	L3
(OR)				
11.	Verify Gauss divergence theorem for $\vec{F} = x^2\vec{i} + y^2\vec{j} + z^2\vec{k}$ where S is the surface of the cube bounded by $x = 0, x = a, y = 0, y = b, z = 0, z = c$.	10M	CO4	L3

LAKIREDDY BALI REDDY COLLEGE OF ENGINEERING (AUTONOMOUS)

L.B.Reddy Nagar :: Mylavaram – 521 230 :: NTR Dist. :: A.P.

B.Tech. (II Semester) Regular/Supplementary Examinations

23FE04-ENGINEERING PHYSICS

(AI&DS,CSE,CSE(AI&ML) and IT)

Boosoo
9/12/25

Time : 3 hours

Max. Marks : 70

Q.No	Compulsory Question	Marks	CO	BL
1(a)	Explain the formation of colours in thin films.	2M	CO1	L2
(b)	State Brewster's law.	2M	CO1	L1
(c)	Define Miller indices and give its importance.	2M	CO2	L2
(d)	What is meant by crystal structure? Give examples.	2M	CO2	L1
(e)	Interpret the complex dielectric constant.	2M	CO3	L2
(f)	What is hysteresis? Notify its importance.	2M	CO3	L1
(g)	State Heisenberg uncertainty principle.	2M	CO4	L1
(h)	Define Fermi level and Fermi energy.	2M	CO4	L2
(i)	Give the applications of Hall effect.	2M	CO5	L1
(j)	Write Einstein's equations for electrons and holes.	2M	CO5	L1
Q.No	All questions carry equal marks	Marks	CO	BL
2(a)	Discuss the Fraunhofer's diffraction due to single slit and obtain the conditions for maximum and minimum intensities.	5M	CO1	L2
(b)	Write a short note on quarter wave plate and half wave plate.	5M	CO1	L2
(OR)				
3(a)	Describe the formation of Newton's rings and explain how the radius of curvature of a plano convex lens can be determined.	5M	CO1	L2
(b)	A parallel beam of light $\lambda=5890 \text{ \AA}$, is incident on a glass plate of refractive index $\mu=1.5$ such that the angle of refraction into the plate is 60° . Calculate the smallest thickness of the plate which will make it appear dark by reflection.	5M	CO1	L3
4(a)	Explain how the crystal structure can be determined by using powder method.	5M	CO2	L2
(b)	X-rays of wavelength 1.5418 \AA are diffracted by (111) planes in a crystal at an angle of 30° in the second order. Estimate the inter planar spacing in the crystal.	5M	CO2	L3
(OR)				
5(a)	Draw the seven crystal systems and the corresponding Bravais lattices with lattice parameters.	5M	CO2	L2
(b)	Show that face centered cubic structure (FCC) is more closely packed than body centered cubic structure (BCC).	5M	CO2	L3
6(a)	Find an expression for ionic polarization of a dielectric material.	5M	CO3	L2
(b)	Elucidate the frequency dependence of dielectric polarization.	5M	CO3	L2
(OR)				
7(a)	Develop an expression for atomic origin of magnetism in magnetic materials.	5M	CO3	L2
(b)	List some important applications of magnetic materials.	5M	CO3	L1
8.	Discuss the motion of an electron in an infinite potential well of width 'a' and obtain its Eigen wave function and Eigen energy values.	10M	CO4	L3
(OR)				
9(a)	Illustrate the Fermi-Dirac's distribution function and its temperature dependence.	5M	CO4	L2
(b)	Highlight the assumptions of classical free electron theory along with the success and drawbacks.	5M	CO4	L1
10(a)	Obtain the equation for electrical conductivity of an intrinsic semiconductor.	5M	CO5	L2
(b)	The Hall coefficient of a specimen was found to be $-7.35 \times 10^{-5} \text{ m}^3/\text{C}$ from 100K to 400K. Calculate the density and mobility of charge carriers if the conductivity was found to be 200 per Ωm .	5M	CO5	L3
(OR)				
11.	Deduce an expression for carrier concentration in an N-type semiconductor and discuss its temperature dependence.	10M	CO5	L3

LAKIREDDY BALI REDDY COLLEGE OF ENGINEERING(AUTONOMOUS)

L.B.Reddy Nagar :: Mylavaram – 521 230 :: NTR Dist.:: A.P.

B.Tech. (II Semester) Regular/Supplementary Examinations

23CS01-INTRODUCTION TO PROGRAMMING

(ASE,CE,ECE,EEE&ME)

Time : 3 hours

Max. Marks : 70

Q.No	Compulsory Question	Marks	CO	BL
1(a)	What is top-down and bottom-up approach?	2M	CO1	L1
(b)	Write unformatted I/O functions in C.	2M	CO3	L1
(c)	Output of the below snippet is: int n=10; for(i=1; i<n; i++) { if (i==5) break; else printf("%d ", i); }	2M	CO5	L3
(d)	Find Odd one among "if", "else", "switch" and "while". Why?	2M	CO2	L2
(e)	List the characteristics of Arrays.	2M	CO1	L2
(f)	How strings are declared and initialized in C?	2M	CO3	L2
(g)	What is realloc() function?	2M	CO4	L1
(h)	Define nested structure with example.	2M	CO4	L1
(i)	What is recursion?	2M	CO5	L1
(j)	Mention the purpose of fopen() and fclose().	2M	CO5	L2
Q.No	All questions carry equal marks	Marks	CO	BL
2(a)	How do you analyze algorithms in problem solving?	5M	CO1	L2
(b)	Write algorithm to display Grade of student based on given marks.	5M	CO2	L3
(OR)				
3.	Define flowchart and explain symbols used in flowcharts. Draw flowcharts for given problems. (i) Find the largest of 3 numbers (ii) compute simple interest.	10M	CO1	L4
4(a)	Develop a C program to find out roots of quadratic equation.	5M	CO3	L3
(b)	Write a C program to check given number is prime or not.	5M	CO3	L3
(OR)				
5.	List all looping/Iterative statements used in C. Explain them with syntax and example.	10M	CO2	L2
6(a)	Define an array. Explain about declaration, initialization, memory representation and accessing of 1D array with an example.	5M	CO3	L1
(b)	Write a C program to implement Bubble sort on array of 10 Integers.	5M	CO5	L3
(OR)				
7(a)	Discuss any 5 string handling functions with examples.	5M	CO3	L2
(b)	Write a C function to generate transpose of a given 2 x 2 matrix.	5M	CO5	L3
8(a)	Define a self-referential structure. Write a c program to create single linked list with three nodes and display the contents.	5M	CO4	L3
(b)	Explain the process of accessing a 1D array using a pointer.	5M	CO4	L2
(OR)				
9(a)	Differentiate Structures and Unions.	5M	CO4	L4
(b)	Write a C program to copy one structure to another.	5M	CO3	L3
10(a)	Define recursion. Write a C program to find factorial of number using recursion.	5M	CO5	L3
(b)	Write a function to swap two numbers using Call by reference technique.	5M	CO5	L3
(OR)				
11(a)	Explain about Random accessing functions in C file handling.	5M	CO4	L2
(b)	Write a C program to copy the contents one file to another file.	5M	CO5	L3

LAKIREDDY BALI REDDY COLLEGE OF ENGINEERING(AUTONOMOUS)

L.B. Reddy Nagar :: Mylavaram - 521 230 :: NTR Dist.:: A.P.

B.Tech. (II Semester) ~~Regular~~/Supplementary Examinations

2300999
5/12/25

23EE01-BASIC ELECTRICAL & ELECTRONICS ENGINEERING

(AI&DS,ASE,CE,CSE,CSE(AI&ML),IT and ME)

Time : 3 hours

Max. Marks: 70

Part - A

Q.No	Compulsory Question	Marks	CO	BL
1(a)	Define Ohm's law.	1M	CO1	L1
(b)	State Faraday's law of electromagnetic induction principle.	1M	CO2	L1
(c)	What are the non-conventional energy resources?	1M	CO3	L1
(d)	State the superposition theorem.	1M	CO1	L1
(e)	List the advantages of the PMMC instrument.	1M	CO2	L1
All questions carry equal marks				
2(a)	Illustrate Kirchoff's Voltage Law with an example.	5M	CO1	L2
(b)	Determine the total resistance and total current in the following circuit	5M	CO1	L3
(OR)				
3(a)	Determine the following parameters of a voltage $v = 200 \sin 314t$. (i) Frequency (ii) Peak value (iii) Time period (iv) RMS value	5M	CO1	L3
(b)	Discuss the following parameters of an AC circuit. (i) Impedance (ii) Power factor (iii) Active Power	5M	CO1	L2
(OR)				
4(a)	Illustrate the principle and working of a single-phase transformer.	5M	CO2	L2
(b)	State and apply Fleming's left-hand rule and Fleming's right-hand rule for a DC machine.	5M	CO2	L2
(OR)				
5(a)	Discuss the working of the PMMC instrument with a neat diagram.	5M	CO2	L2
(b)	Distinguish between moving coil and moving iron instruments.	5M	CO2	L2
(OR)				
6.	Draw the layout and discuss the operation of nuclear power generation.	10M	CO3	L2
(OR)				
7(a)	Describe the working of a fuse with neat diagram.	5M	CO3	L2
(b)	Calculate the electricity bill amount for a month of 31 days, if the following devices are used: (i) 3 bulbs of 30 watts for 5 hours (ii) 4 tube lights of 50 watts for 8 hours (iii) 1 fridge of 300 watts for 24 hours The rate of electrical energy per unit is Rs. 2.	5M	CO3	L3

23EE01-BASIC ELECTRICAL & ELECTRONICS ENGINEERING

Part – B				
Q.No	Compulsory Question	Marks	CO	BL
8(a)	Draw the symbol of an NPN transistor with its terminals.	1M	CO4	L1
(b)	What is an amplifier?	1M	CO5	L1
(c)	What is the use of parity bits in digital communication?	1M	CO6	L1
(d)	What is the Zener effect?	1M	CO4	L1
(e)	Write the truth table of AND gate.	1M	CO6	L1
Q.No	All questions carry equal marks	Marks	CO	BL
9(a)	Discuss the evolution of electronics from vacuum tubes to nanoelectronics.	5M	CO4	L2
(b)	Describe the working of the Zener diode with a neat diagram.	5M	CO4	L2
(OR)				
10(a)	Discuss the input and output characteristics of CE configuration.	5M	CO4	L2
(b)	Illustrate the connections of CB and CC configuration.	5M	CO4	L2
11.	Describe the frequency response of common emitter RC coupled amplifier.	10M	CO5	L2
(OR)				
12(a)	What are the main parts of the DC power supply system? Discuss.	5M	CO5	L2
(b)	Draw the waveforms of the full wave bridge rectifier and write its applications.	5M	CO5	L2
13(a)	Convert the following number systems (i) $(110101)_2 = (?)_{10}$ (ii) $(25)_{10} = (?)_2$	5M	CO6	L2
(b)	Discuss the functionality of the following gates with the truth tables. (i) NOT (ii) OR (iii) Ex-NOR	5M	CO6	L2
(OR)				
14(a)	Describe the operation of the clocked SR flip-flop.	5M	CO6	L2
(b)	Describe the operation of a 2-bit counter using JK flip-flops.	5M	CO6	L2

LAKIREDDY BALI REDDY COLLEGE OF ENGINEERING(AUTONOMOUS)

L.B. Reddy Nagar :: Mylavaram – 521 230 :: NTR Dist.:: A.P.

B.Tech. (II Semester) ~~Regular~~/Supplementary Examinations**23CM01-BASIC CIVIL AND MECHANICAL ENGINEERING**

(ECE & EEE)

Time : 3 hours

Max. Marks: 70

Part - A

Q.No	Compulsory Question	Marks	CO	BL
1(a)	Define sill level of a building.	1M	CO1	L1
(b)	Define surveying.	1M	CO2	L1
(c)	What is the significance of terminal building in airport?	1M	CO4	L1
(d)	The bearing 175° observed for line AB, then what is its Quadrantal bearing.	1M	CO2	L1
(e)	List the different types of railway gauges.	1M	CO4	L1
Q.No	All questions carry equal marks	Marks	CO	BL
2(a)	List the various types of bricks and explain.	5M	CO3	L2
(b)	Write a short note on Reinforced concrete structures.	5M	CO3	L2
(OR)				
3(a)	Explain scope of the following branches of civil engineering: (i) Environmental Engineering. (ii) Geotechnical Engineering.	5M	CO1	L2
(b)	List out the various types of cement and explain any two of them.	5M	CO1	L2
4.	The following readings are successively taken with a level 0.655, 0.875, 1.565, 1.35, 1.65, 1.445, 1.95, 2.45, 2.355, 0.835, 1.935, 1.855 and 3.45. The instrument is shifted after the 3 rd and 6 th readings. Prepare a level book and calculate all reduced levels of different points. The RL of the 1 st point is 150.50 m. Use HI and rise and fall method.	10M	CO2	L3
(OR)				
5(a)	Define the following terms, (i) Whole circle bearing and Reduced bearing (ii) Fore bearing and Back bearing (iii) True meridian and magnetic meridian	5M	CO2	L2
(b)	The following fore bearings were observed for lines, AB, BC, CD, DE, EF, and FG respectively. Determine their back bearings: (i) 148° (ii) 65° (iii) 285° (iv) 215° (v) N 36° W (vi) S 40° E	5M	CO2	L2
6(a)	Differentiate between Flexible pavement and Rigid pavement.	5M	CO4	L2
(b)	List and explain various sources of surface water ground water.	5M	CO5	L2
(OR)				
7(a)	Explain the following. (i) Evapotranspiration (ii) Runoff	5M	CO5	L2
(b)	Explain the advantages and disadvantages of Rainwater harvesting.	5M	CO5	L2

Part - B

Q.No	Compulsory Question	Marks	CO	BL
8(a)	What is the carbon percentage in cast iron?	1M	CO1	L1
(b)	Write applications of smart materials.	1M	CO1	L1
(c)	Write the applications of joining process.	1M	CO2	L1
(d)	Define compression ratio.	1M	CO2	L1
(e)	List out any two power plants.	1M	CO3	L1
Q.No	All questions carry equal marks	Marks	CO	BL
9(a)	Explain the role of mechanical engineering in energy sector.	5M	CO1	L2
(b)	List out the applications of ferrous materials.	5M	CO1	L1
(OR)				
10.	Discuss the composite materials with a neat sketch.	10M	CO1	L2
11(a)	Illustrate the different types of machining process.	5M	CO1	L3
(b)	Enumerate applications of smart manufacturing process.	5M	CO1	L2
(OR)				
12(a)	Differentiate between 4-stroke engine and 2-stroke engine.	5M	CO2	L2
(b)	Define boiler and explain the importance of boilers.	5M	CO2	L2
13(a)	Illustrate the working principle of nuclear power plant.	5M	CO3	L3
(b)	Explain the gear drives with a neat sketch.	5M	CO3	L2
(OR)				
14(a)	Classify the power transmission systems.	5M	CO3	L2
(b)	Discuss the cylindrical robot configuration with a neat sketch.	5M	CO4	L2

06 DEC 2025

H.T.No

R23

LAKIREDDY BALI REDDY COLLEGE OF ENGINEERING (AUTONOMOUS)

L.B.Reddy Nagar :: Mylavaram - 521 230 :: NTR Dist. :: A.P.

B.Tech. (II Semester) Regular/Supplementary Examinations

23CS02-DATA STRUCTURES
(AI&DS,CSE,CSE(AI&ML) and IT)

Time : 3 hours

Max. Marks : 70

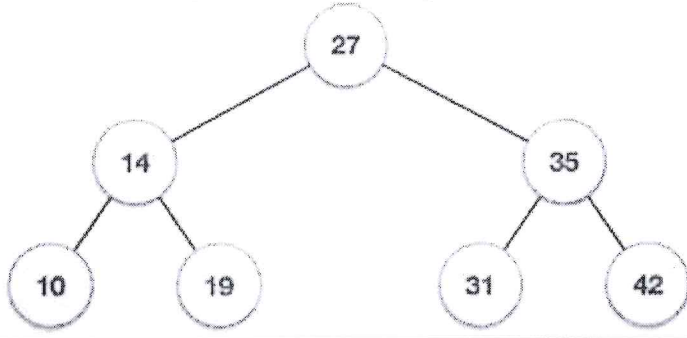
Q.No	Compulsory Question	Marks	CO	BL
1(a)	Find the step count for the following code segment <pre>for(I=0;I<n;I++) { S=0; for(j=0;j<I;j++) { S=S+I+j; printf("%d",S); } }</pre>	2M	CO1	L2
(b)	Define Big-oh notation.	2M	CO1	L1
(c)	What is the primary disadvantage of a linked list compared to an array?	2M	CO2	L2
(d)	Write C function to count number of nodes in singly linked list.	2M	CO2	L3
(e)	Define stack? List operations performed by stack.	2M	CO3	L1
(f)	Draw the stack for the below sequence of operations Push(8), Push(9), pop(),push(12), pop()	2M	CO3	L2
(g)	Define double ended queue and list operations.	2M	CO4	L2
(h)	List applications of queue.	2M	CO4	L2
(i)	Insert the elements 32, 6 and 15 into given binary search tree. 	2M	CO5	L2
(j)	Discuss the importance of hashing.	2M	CO5	L2
Q.No	All questions carry equal marks	Marks	CO	BL
2(a)	Elaborate different types of data structures with suitable examples.	5M	CO1	L3
(b)	Write a C program to search key element from the list using binary search.	5M	CO1	L2
(OR)				
3(a)	Discuss the procedure to sort elements using selection sort and arrange the given elements: 90,67,32,98,57,12,5,45,89.	5M	CO1	L4
(b)	Write a C program to arrange the array elements in sorted order using insertion sort.	5M	CO1	L3
4.	Create a linked list of books with book name, author name, pages and price. Your program should add a new book details, delete an existing book name & display all the books details.	10M	CO3	L3

(OR)

23CS02-DATA STRUCTURES

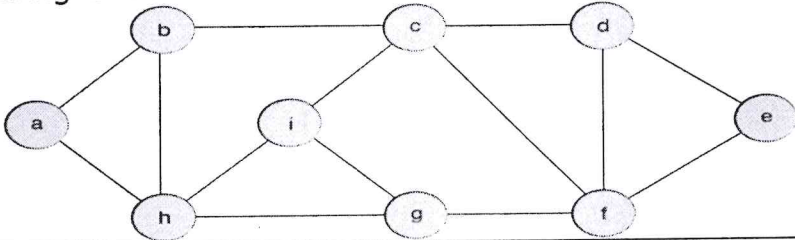
5(a)	Discuss about different operations performed on single linked list with suitable example.	5M	CO2	L2										
(b)	Write C Functions to implement the following in DLL. (i) Deletion at end (ii) Insertion at begin.	5M	CO2	L3										
(OR)														
6(a)	Convert the given infix expression into post-fix expression using stack $A*B/(C-D*E)+F*G$.	5M	CO4	L3										
(b)	Write a C Program to implement stack operations using linked list.	5M	CO2	L3										
(OR)														
7(a)	Evaluate the given prefix expression using stack $+ + 2 6 + - 5 6 4$	5M	CO4	L3										
(b)	Write a C program for checking balancing of symbols using stack.	5M	CO3	L3										
(OR)														
8(a)	Consider the Double ended queue given below which has front=1, rear=5 <table border="1" style="margin: 10px auto; width: 50%;"> <tr> <td style="width: 20px; height: 20px;"></td> <td style="width: 20px; height: 20px; text-align: center;">A</td> <td style="width: 20px; height: 20px; text-align: center;">B</td> <td style="width: 20px; height: 20px; text-align: center;">C</td> <td style="width: 20px; height: 20px; text-align: center;">D</td> <td style="width: 20px; height: 20px; text-align: center;">E</td> <td style="width: 20px; height: 20px;"></td> <td style="width: 20px; height: 20px;"></td> <td style="width: 20px; height: 20px;"></td> <td style="width: 20px; height: 20px;"></td> </tr> </table> <p>Now perform the following sequence and find front and rear values for each operation (i) ADD F on front (ii) ADD G on rear (iii) ADD H on front (iv) DELETE one alphabet from front (v) ADD I on rear (vi) ADD J on front (v) DELETE 2 alphabets from rear.</p>		A	B	C	D	E					5M	CO4	L3
	A	B	C	D	E									
(b)	Write a C Program to implement various operations on circular queue using arrays.	5M	CO2	L3										
(OR)														
9(a)	Discuss about different operations performed on queue with suitable diagrams.	5M	CO2	L2										
(b)	Apply Breadth First Search (BFS) for the given graph by considering 'b' as source vertex. 	5M	CO4	L3										
(OR)														
10.	What is Binary Search Tree? Discuss different types of operations performed on binary search tree with suitable examples.	10M	CO3	L2										
(OR)														
11(a)	Construct Binary Tree for the given tree traversals In order: T S Q A E D P M X C R F Post order: T Q S D E A M C F R X P.	5M	CO4	L3										
(b)	Discuss the following with suitable example (i) Linear Probing (ii) Double Hashing.	5M	CO5	L2										

LAKIREDDY BALI REDDY COLLEGE OF ENGINEERING (AUTONOMOUS)

L.B.Reddy Nagar :: Mylavaram - 521 230 :: NTR Dist. :: A.P.
B.Tech. (II Semester) Regular/Supplementary Examinations

23ME02-ENGINEERING MECHANICS
(ASE,CE&ME)

Time : 3 hours

Max. Marks: 70

Q.No	Compulsory Question	Marks	CO	BL
1(a)	Define the Moment of force and mention its units.	2M	CO1	L1
(b)	State the triangle law of forces with a supporting diagram.	2M	CO1	L2
(c)	Exemplify the equilibrium.	2M	CO2	L1
(d)	Define the cone of friction with a suitable diagram.	2M	CO2	L2
(e)	Define area moment of inertia.	2M	CO3	L2
(f)	State Parallel Axis Theorem.	2M	CO3	L1
(g)	Define rectilinear translations with suitable examples.	2M	CO4	L2
(h)	State Work- Energy Principle.	2M	CO4	L1
(i)	A rigid body is translating with a constant velocity of 5 m/s. What is the acceleration of the body.	2M	CO5	L2
(j)	A rigid body rotates about a fixed axis with an angular velocity of 4 rad/s. What is the angular displacement after 2 seconds if the angular acceleration is 0 rad/s ² .	2M	CO5	L2

Q.No	All questions carry equal marks	Marks	CO	BL
2(a)	State and prove Varignon's theorem with a neat diagram.	5M	CO1	L2
(b)	Evaluate the resultant of the following force system shown in the figure. And also convert the same force system into a single force system and a couple at point A.	5M	CO1	L3

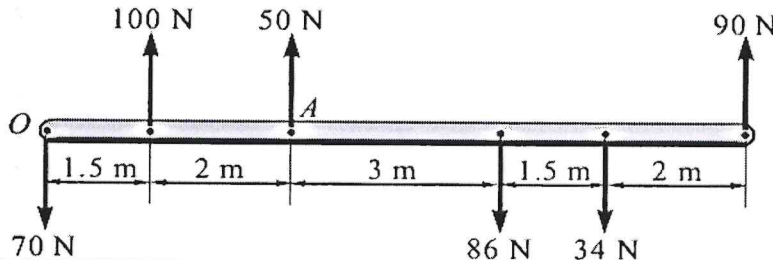

(OR)

3.	The resultant of forces P and Q acting at an angle ' θ ' is equal to $(2n + 1)\sqrt{P^2 + Q^2}$ and when they act at angle $(90 - \theta)$, the resultant is $(2n - 1)\sqrt{P^2 + Q^2}$. Show that $\tan \theta = \frac{(n-1)}{(n+1)}$.	10M	CO1	L4
----	---	-----	-----	----

4.	Two identical rollers, each of weight $Q=100\text{N}$, are supported by an inclined plane and a vertical wall, as shown in the figure given below. Assuming smooth surfaces, evaluate the reactions induced at the points of support A, B, and C.	10M	CO2	L3
----	--	-----	-----	----

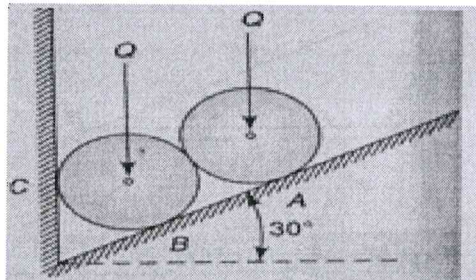

(OR)

5(a)	Write Coulomb's laws of friction.	5M	CO2	L2
(b)	A body of weight 800N is to be push up an inclined plane of angle 25°. Estimate the minimum force required parallel to inclined plane.	5M	CO2	L3

23ME02-ENGINEERING MECHANICS

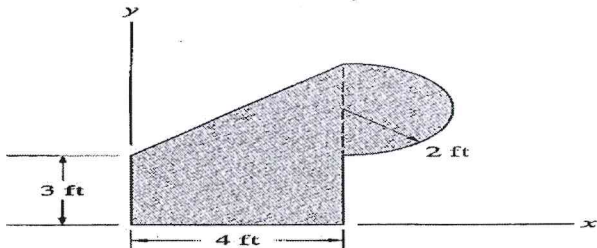
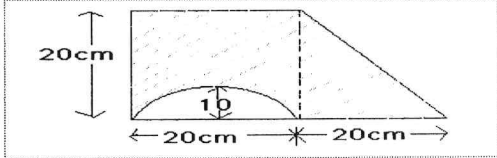
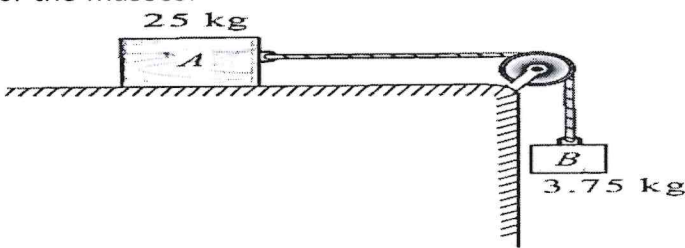
6(a)	Identify the centroid coordinates of the plane area shown in the figure. 	5M	CO3	L3
(b)	Show that the moment of inertia of a semicircular area of radius 'R' is $0.11R^4$ with respect to the centroidal axis parallel to the diameter.	5M	CO3	L3
(OR)				
7.	Determine the moment of inertia of the following figure with respect to the centroidal axis and bottom layer of the plane flange. 	10M	CO3	L3
8(a)	Derive the equations of motion of a particle, when a particle moves by a displacement (s), initial velocity (u) and final velocity (v) after t seconds under constant acceleration (a).	5M	CO4	L3
(b)	A particle starts moving along a straight line with an initial velocity of 25m/sec from point O under a uniform acceleration of -2.5m/s^2 . Determine (i) the velocity, displacement, and distance traveled in 5 seconds and (ii) how long the particle moves in the same direction.	5M	CO4	L3
(OR)				
9(a)	Evaluate the time required for a car to travel 1km along a road if the car starts from rest, reaches a maximum speed at some intermediate point, and then stops at the end of the road. The car can accelerate or decelerate at 1.5m/s^2 .	5M	CO4	L3
(b)	The equation for angular displacement of a body moving on a circular path is given by $\theta = 2t^3 + 0.5$, where θ is in rad/sec and t in sec. Evaluate the angular velocity, displacement and acceleration after 2 sec.	5M	CO4	L3
10(a)	A multiple-unit electric train has 800tonnes mass. The resistance to motion is 100 N per tonne of the train mass. If the electric motors can provide 200kN tractive force, how long does it take to accelerate the train to a speed of 90km/hr from rest.	5M	CO5	L3
(b)	A body of mass 10kg is moving over a smooth surface, whose equation of motion is given by the relation $s = 5t + 2t^2$ where (s) is in meters and (t) in seconds. Find the magnitude of force responsible for the motion.	5M	CO5	L3
(OR)				
11.	A body of 25kg mass resting on a horizontal table is connected by string passing over a smooth pulley at the edge of the table to another body of 3.75kg mass and hanging vertically as shown in figure. Initially, the friction between 25kg mass and the table is just sufficient to prevent the motion. If an additional 1.25kg is added to the 3.75kg mass, find the acceleration of the masses. 	10M	CO5	L4

LAKIREDDY BALI REDDY COLLEGE OF ENGINEERING (AUTONOMOUS)

L.B. Reddy Nagar :: Mylavaram – 521 230 :: NTR Dist. :: A.P.
 B.Tech. (II Semester) Regular/Supplementary Examinations

Answered
6/12/24

23EC01-NETWORK ANALYSIS
 (ECE)

Time : 3 hours

Max. Marks : 70

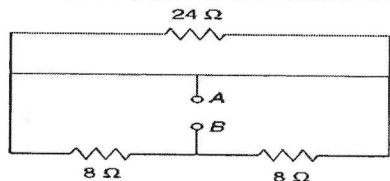
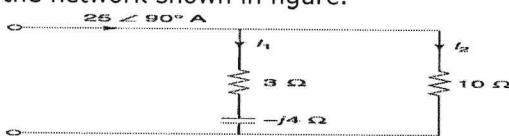
Q.No	Compulsory Question	Marks	CO	BL
1(a)	Find the resistance between terminals A and B in the network shown in figure. 	2M	CO1	L3
(b)	Explain principle of Duality in electrical circuit.	2M	CO1	L2
(c)	Define transient time and transient response in electrical circuits.	2M	CO2	L1
(d)	Define time constant of series RL circuit.	2M	CO2	L1
(e)	Write different forms of mathematical representations of phasors.	2M	CO3	L1
(f)	Find currents I_1 and I_2 in the network shown in figure. 	2M	CO3	L3
(g)	Derive an expression for resonant frequency in series RLC circuit.	2M	CO4	L3
(h)	Two coils having self-inductances of 4 mH and 7 mH respectively are connected in parallel. If the mutual inductance between them is 5 mH, find the equivalent inductance.	2M	CO5	L3
(i)	Draw the general two-port network model also write the network variables.	2M	CO6	L1
(j)	Define an attenuator having fixed attenuation.	2M	CO6	L1

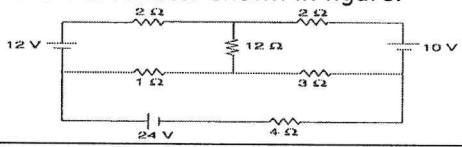
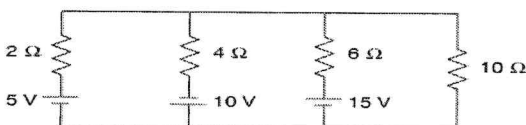
Q.No	All questions carry equal marks	Marks	CO	BL
2(a)	Find the current through the 4 ohm resistor shown in figure. 	5M	CO1	L3
(b)	Find the current through the 10 resistor in the network of figure using Milliman's theorem. 	5M	CO1	L3

(OR)

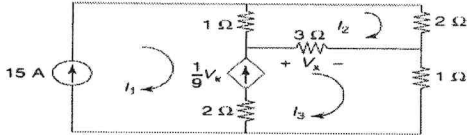
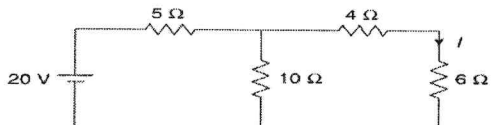
3(a)	Find the currents I_1 , I_2 , and I_3 in the network shown in figure. 	5M	CO1	L3
(b)	Calculate current I and verify the reciprocity theorem for the network shown in figure. 	5M	CO1	L3

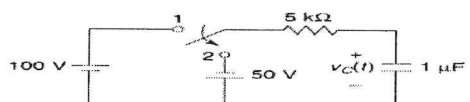
4(a)	State and prove initial and final value theorems.	5M	CO2	L3
(b)	The switch in the circuit of figure is moved from the position 1 to 2 at $t = 0$. Find $V_C(t)$. 	5M	CO2	L3

(OR)

23EC01-NETWORK ANALYSIS

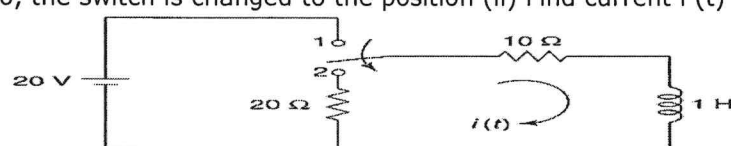
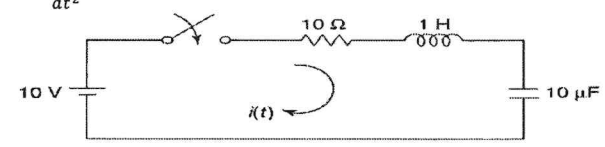
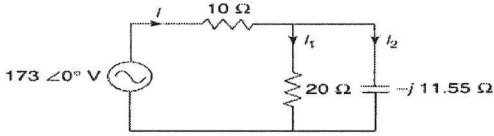
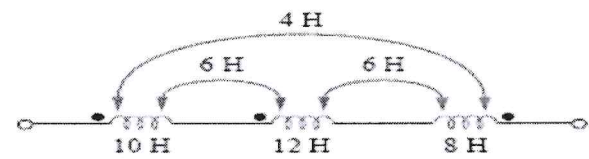
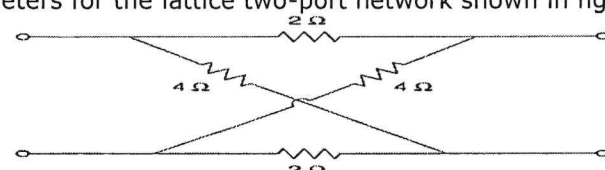
5(a)	<p>In the network shown in figure, the switch is initially at the position (i) for a long time. At $t = 0$, the switch is changed to the position (ii) Find current $i(t)$ for $t > 0$.</p> 	5M	CO2	L3
(b)	<p>In the network of figure, the switch is closed at $t = 0$. With the capacitor uncharged, find value for i, $\frac{di}{dt}$ and $\frac{d^2i}{dt^2}$ and at $t = 0^+$.</p> 	5M	CO2	L3
(OR)				
6.	<p>Analyze the behavior of pure resistor, inductor and capacitor in frequency domain with the help of phasor diagrams.</p>	10M	CO3	L4
(OR)				
7(a)	<p>For the circuit shown in figure, evaluate the current through and voltage across each element.</p> 	5M	CO3	L3
(b)	<p>An alternating voltage of $80 + j60$ V is applied to a circuit and the current flowing is $4 - j2$ A. Find the (i) impedance, (ii) phase angle, (iii) power factor, and (iv) power consumed.</p>	5M	CO3	L3
8(a)	<p>Determine the impedance of series RLC circuit with $R=12\Omega$, $L=0.15H$, $C=22\mu F$ at resonant frequency, 10Hz below resonant frequency and 10Hz above resonant frequency.</p>	5M	CO4	L3
(b)	<p>Derive an expression for equivalent inductance, when two inductors are connected in series-aiding.</p>	5M	CO5	L3
(OR)				
9(a)	<p>Demonstrate series RLC resonant circuit with the help of current, impedance, reactance curves.</p>	5M	CO4	L4
(b)	<p>Calculate the equivalent inductance of the three series connected inductors.</p> 	5M	CO5	L3
10(a)	<p>Determine the Z-Parameters in terms of ABCD parameters of a given two-port network.</p>	5M	CO6	L3
(b)	<p>Design a n-type attenuator to give attenuation of 20 dB and characteristic resistance of 500Ω.</p>	5M	CO6	L3
(OR)				
11(a)	<p>Evaluate Z, Y, ABCD parameters by using currents I_1 and I_2 entering at port 1 and port 2 respectively of a two port network. $I_1=0.8V_1-0.4V_2$ $I_2=-0.2V_1+0.5V_2$</p>	5M	CO6	L3
(b)	<p>Find image parameters for the lattice two-port network shown in figure.</p> 	5M	CO6	L3

LAKIREDDY BALI REDDY COLLEGE OF ENGINEERING (AUTONOMOUS)L.B.Reddy Nagar :: Mylavaram – 521 230 :: NTR Dist. :: A.P.
B.Tech. (II Semester) - Regular/Supplementary ExaminationsBoseep
6/12/25**23EE02-ELECTRICAL CIRCUIT ANALYSIS-I**
(EEE)

Time : 3 hours

Max. Marks : 70

Q.No	Compulsory Question	Marks	CO	BL
1(a)	What is the difference between mesh and loop in a circuit.	2M	CO3	L1
(b)	State Kirchoff's laws.	2M	CO3	L1
(c)	Define magnetic circuit.	2M	CO2	L1
(d)	State Ohm's of magnetism.	2M	CO2	L1
(e)	Draw an impedance triangle for a series R-L circuit and derive an expression for phase angle from the impedance triangle.	2M	CO3	L2
(f)	What is the angular velocity of a sine wave having a frequency of 50 Hz?	2M	CO3	L2
(g)	Draw the current locus diagram of a series R-L circuit as L varies from 0 to infinity.	2M	CO4	L2
(h)	What are the characteristics of a series resonant circuit?	2M	CO4	L2
(i)	What is the Maximum Power Transfer theorem?	2M	CO5	L2
(j)	How does the Compensation theorem help to analyze a circuit?	2M	CO5	L2

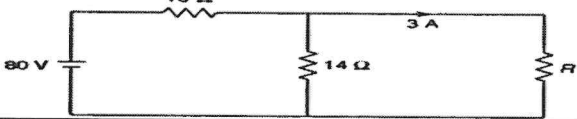
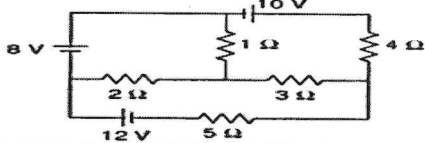
Q.No	All questions carry equal marks	Marks	CO	BL
2(a)	In the Fig. below, find the value of R. 	5M	CO1	L3
(b)	Use mesh analysis and determine the current through the 5 Ω resistor of the network shown in Fig. below. 	5M	CO3	L4

(OR)

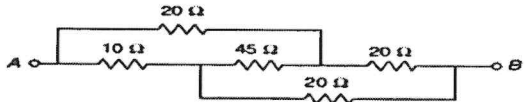
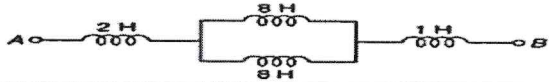
3(a)	Find the equivalent resistance between the terminals A and B in the network shown below. 	5M	CO1	L3
(b)	What is the equivalent inductance between the terminals A and B in the network of Fig. below. 	5M	CO1	L3

4.	An iron ring has a cross section of 3 cm^2 and a mean diameter of 25 cm. An air-gap of 0.4 mm has been cut across the section of the ring. The ring is wound with a coil of 200 turns through which a current of 2 A is passed. If the total magnetic flux is 0.24 milli Wb, find the relative permeability of iron, assuming no magnetic leakage.	10M	CO2	L4
----	--	-----	-----	----

(OR)

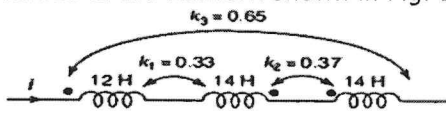
5(a)	When two coils are connected in series, their effective inductance is found to be 10.0 H. However, when the connections to one coil are reversed, the effective inductance is 6.0 H. If the coefficient of coupling is 0.6, calculate the self-inductance of each coil and the mutual inductance.	5M	CO2	L3
(b)	Find the equivalent inductance of the network shown in Fig. below. 	5M	CO2	L3

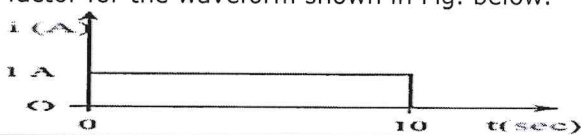
6(a)	Calculate the form factor for the waveform shown in Fig. below. 	5M	CO3	L3
------	---	----	-----	----

23EE02-ELECTRICAL CIRCUIT ANALYSIS-I

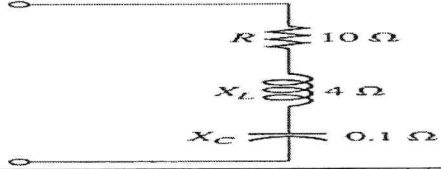
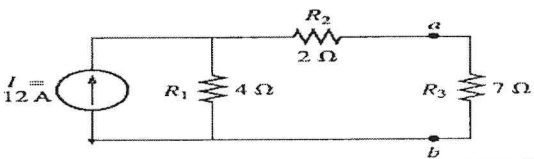
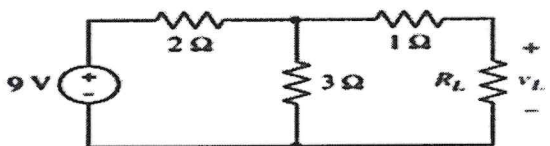
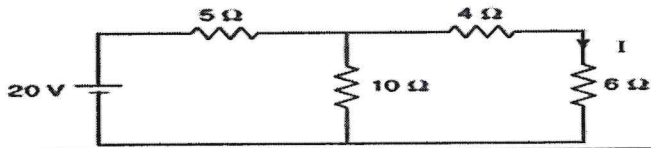
(b)	An alternating voltage has the equation $v = 141.4 \sin 377t$; determine the values of: (i) R.M.S. voltage; (ii) frequency; (iii) the instantaneous voltage when $t = 3$ milli seconds.	5M	CO3	L3
(OR)				
7(a)	Given a circuit with an applied voltage $v = 340 \sin (\omega t - 60^\circ)$ (V) and a resulting current $i = 13.3 \sin (\omega t - 50^\circ)$ (A), determine the active, reactive and apparent powers.	5M	CO3	L3
(b)	For the series connected elements in Fig. below, find the total impedance and total admittance in polar form.	5M	CO1	L3
				
8(a)	Prove that the locus of current drawn by a series R-C circuit of constant resistance and variable capacitive reactance is a circle when the supply voltage and frequency are constant.	5M	CO4	L2
(b)	An AC circuit consists of a variable resistor in series with an inductor $L = 0.1$ H. When the supply voltage is 100V and the frequency is 50Hz, calculate (i) the radius of the current locus, and (ii) the value of the variable resistor in order that the power taken from the supply may be a maximum.	5M	CO4	L4
(OR)				
9(a)	A series R-L-C circuit is connected to a 200 V AC supply. The current drawn by the circuit at resonance is 20 A. The voltage drop across the capacitor is 5000 V at series resonance. Calculate resistance and inductance if capacitance is 4 μ F. Also, calculate the resonant frequency.	5M	CO4	L4
(b)	A capacitor is connected in parallel with a coil having $L = 5.52$ mH and $R = 10 \Omega$, to a 100-V, 50-Hz supply. Calculate the value of the capacitance for which the current taken from the supply is in phase with voltage.	5M	CO4	L4
10(a)	Find the Thevenin equivalent circuit for the network in the Fig. below and determine the current flowing through the resistance R_3 .	5M	CO5	L4
				
(b)	Find the value of the load resistance R_L which results in maximum power transfer from the source to the load for the circuit shown in Fig. below.	5M	CO5	L4
				
(OR)				
11(a)	Calculate current I and verify the Reciprocity theorem for the network shown in Fig. below.	5M	CO5	L4
				
(b)	In the network of Fig. below, the impedance $(3+j2) \Omega$ is changed to $(5+j3) \Omega$. Determine the change in current in the $(5+j3) \Omega$ using the Compensation theorem.	5M	CO5	L4
